



KBP005G THRU KBP10G

Glass Passivated Bridge Rectifiers

Reverse Voltage - 50 to 1000 Volts

Forward Current - 1.5 Amperes

Features

- Glass passivated chip
- Low forward voltage drop
- Ideal for printed circuit board
- Meet UL flammability classification 94V-0

Mechanical Data

- Polarity: Symbol marked on body
- Mounting position: Any

Applications

- General purpose use in AC/DC bridge full wave rectification, for home appliances, office equipment, etc.

SG-KBP

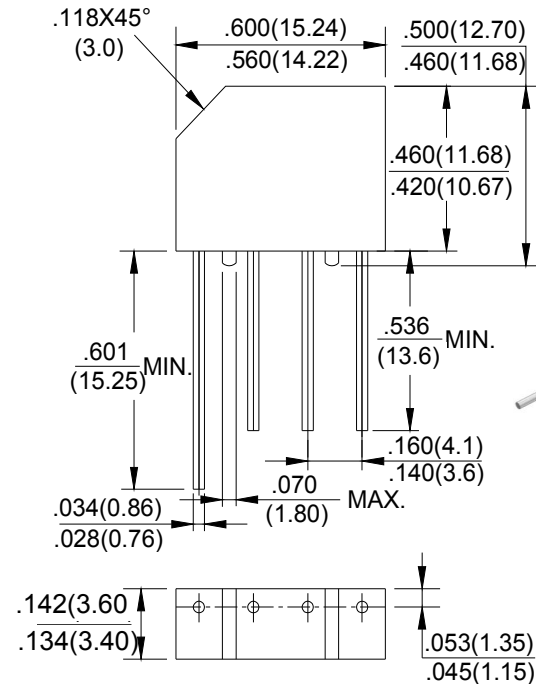

RoHS COMPLIANT

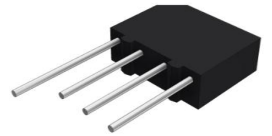

Package Outline Dimensions in Inches (Millimeters)

Maximum Ratings and Electrical Characteristics

Rating at 25°C ambient temperature unless otherwise specified.

Single phase, half wave, 60Hz, resistive or inductive load.

For capacitive load, derate current by 20%.

Characteristics	Symbol	KBP005G	KBP01G	KBP02G	KBP04G	KBP06G	KBP08G	KBP10G	Unit
Maximum Repetitive Peak Reverse Voltage	V _{RRM}	50	100	200	400	600	800	1000	V
Maximum RMS Voltage	V _{RMS}	35	70	140	280	420	560	700	V
Maximum DC Blocking Voltage	V _{DC}	50	100	200	400	600	800	1000	V
Maximum Average Forward Rectified Current @T _A =50 °C	I _(AV)	1.5							A
Peak Forward Surge Current, 8.3mS Single Half Sine-Wave, Superimposed on Rated Load (JEDEC Method)	I _{FSM}	50							A
I ² t Rating for Fusing (t<8.3mS)	I ² t	10.4							A ² s
Peak Forward Voltage per Diode at 1.5A DC	V _F	1.1							V
Maximum DC Reverse Current at Rated @T _J =25°C	I _R	10							µA
DC Blocking Voltage per Diode @T _J =100°C		1.0							mA
Operating Junction Temperature Range	T _J	-55 to +150							°C
Storage Temperature Range	T _{STG}	-55 to +150							°C

Rating and Characteristic Curves

KBP005G THRU KBP10G



Fig. 1 - Forward Current Derating Curve

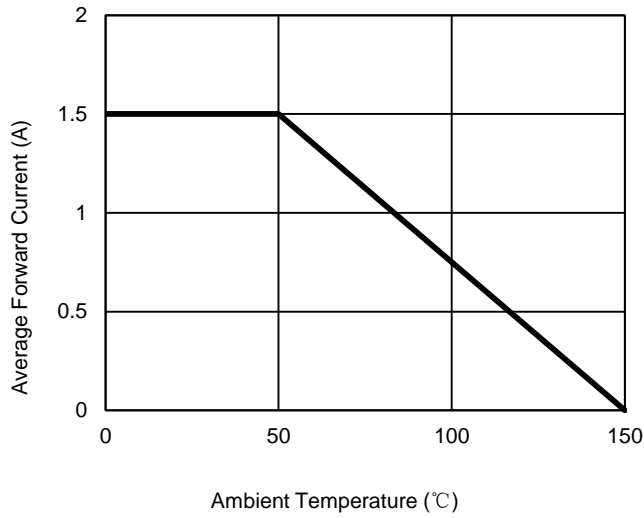

Fig. 2 - Maximum Non-Repetitive Surge Current

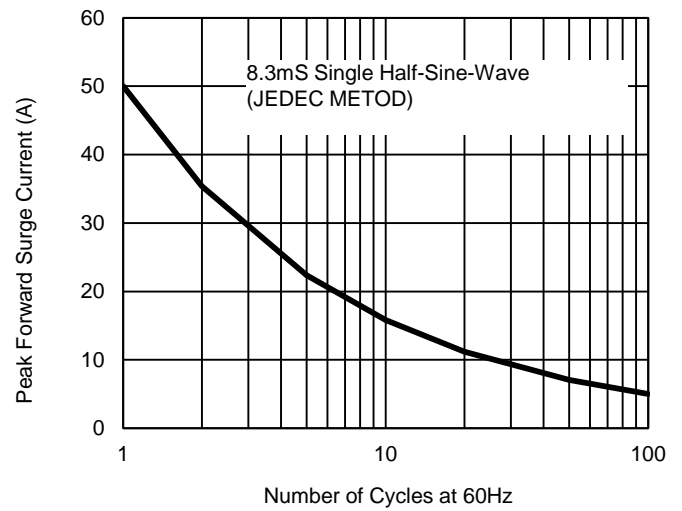

Fig. 3 - Typical Reverse Characteristics

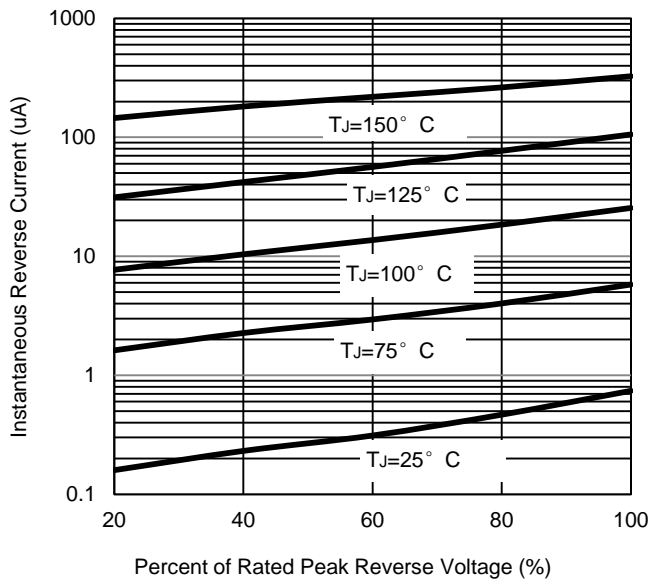
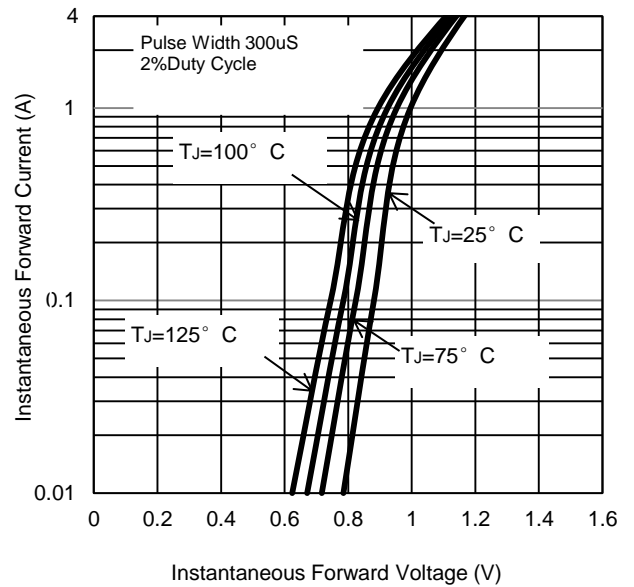

Fig. 4 - Typical Forward Characteristics



The curve above is for reference only.